



Lottery Product Requirements & Specifications for Equipment Placement

Below are the equipment components for Lottery Product. Equipment installed in your location will vary with the type of business you have.

Component Definitions:

Retailer Compact: Clerk operated terminal

Window Jackpot Sign: Displays Powerball, Mega Millions, Oregon’s Game Megabucks, draw times and jackpot amounts.

Game Touch 28 & 20: Player operated terminals

WinCheck: Device used by customer to see if ticket is a winner

Printer: Thermal printer for clerk operated terminal

Monitor: 32” or 43”

Installation and service of the above devices provided by IGT.

Router: A network device used to direct electronic communication from one device on a network to another device on a network.

Terminal Type	Height (in inches)	Width (in inches)	Depth (in inches)	Weight (in lbs)	VAC	Start Up Amps
Retailer Compact	14.6	9.8	11.3	9.8	120	3.0
Printer	5.81	5.75	7.75	4	120	1.5
Game Touch 28(GT28)	74.0	35.3	27.2	812	120	3.0
Game Touch 20(GT20)	54.0	38.3	28.8	700	120	3.0
WinCheck with Base	12.03 12.47	6.73 7.45	3.58 4.85	3.1 3.6	120	0.5
Retailer Pro	16.0	14.2	15.9	37	120	1.5
HP Router 1841	1.75	13.5	10.5	6.41	120	1.0
Play Center	54	20	20	62	NA	NA
Window Jackpot Sign	19	14	4	3.6	120	2.0
ShowController					120	0.5

Note: Win Check should be 36 inches from the ground for ADA

System Wiring Requirements –

IGT is the Lottery Product Portfolio vendor who provides the communication wiring between equipment components. Use of a licensed electrical contractor to obtain all permits and install all electrical service wiring is strongly recommended. Unauthorized alteration, repairs, or tampering with telephone communication or electrical service wiring may result in interrupted service and a charge for repairs.

Input power and outlet –

Lottery Product equipment components require one dedicated 20-amp circuit with three wire grounded standard wall outlets. The number and location of the Draw Game System components determine the number of outlets.

The Lottery Area Logistics Specialist will contact new retailers to schedule a planning meeting with the retailer, the licensed electrical contractor and Lottery Field Sales and IGT Customer Service Representatives to plan the installation of the Lottery Product Equipment. If you have questions, or you need to relocate equipment, contact the Lottery Area Logistics Specialist two weeks prior to the move. For additional assistance, please call 1-800-766-6789.

TYPICAL WIRING DIAGRAM

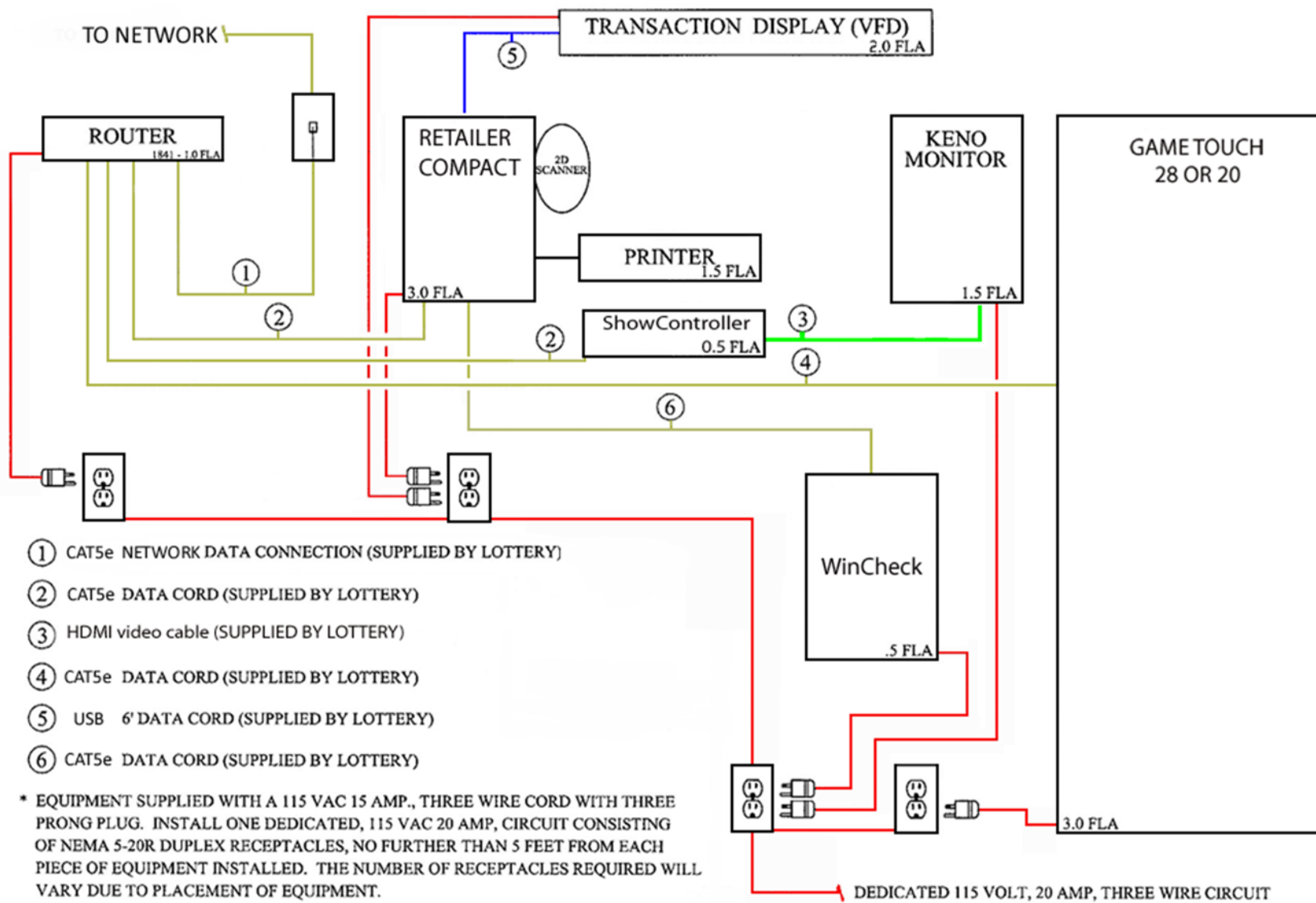

12/02/20